



**L.T.F.**

## QLUX Light Tune COB LED Series



# QLUX COB

**LTCOBi1313905727 Dual Channel  
Color Tunable Chip on Board LED**



<b>Size</b>	13.25mm x 13.25mm
<b>LES</b>	6 mm (OD)
<b>Maximum Voltage</b>	10V
<b>Typical Power</b>	≈ 6.3W
<b>Typical Efficacy</b>	≈ 100 lm/W
<b>Channels</b>	Dual
<b>Tunable CCT</b>	2200K-6600K
<b>Typical CRI</b>	90+
<b>Maximum Lumens</b>	≈ 315 lm



**RoHS**



L.T.F.'s U.S. Patented QLUX Light Tune Series COB LEDs offer endless possibilities for lighting OEMs and designers. With industry leading adjustable CCT range, high efficacy, superior color rendering and best color over angle performance built into all QLUX LED light sources. Light Tune COBs let you dial in the perfect illumination for any architectural lighting application.

### FEATURES

- Wide adjustable CCT range, ideal for human-centric lighting projects.
- Superior color rendering performance throughout CCT and dimming ranges.
- Excellent color uniformity and best color over angle with TIR optics.
- Customizable CCT and dimming curve options.
- Proven reliability; LM-80 9,000 hours completed.
- Cost effective.
- Low thermal resistance with long time reliability.
- Dial in vibrant, cool CCT light for tasks requiring focus and energy, or promoting wakefulness in night shift workers.
- Transition to warm, cozy ambient light, to avoid blue light exposure before sleep.

### APPLICATIONS

- Human-centric lighting
- Circadian lighting
- Architectural lighting
- Spot lights
- Down lights
- Pendants

### SPECIFICATIONS

Tunable CCT	Power	Current		Voltage		Luminous Flux	CRI	R9
		Warm If (mA)	Cool If (mA)	Warm Vf (V)	Cool Vf (V)			
Warm Channel Only - 2200K	2.4W	280mA	--	8.6V	--	210 lm	93	60
Cool Channel Only - 6600K	2.6W	--	300mA	--	8.7V	315 lm	92	69



**LTCOBi1313905727 Dual Channel  
Color Tunable Chip on Board LED**

**MECHANICAL SPECIFICATIONS**

Dimensions	Light Emitting Surface
13.25mm x 13.25mm	6mm (OD)

**3D Models Available**

To aid in OEM product design, 3D models of this QLUX Light Tune COB LED are available for download as:

.STEP and .OBJ files (.zip download)

**IESNA Photometric Data Available**

IES Report (.pdf download)

IES Test Data (.zip download)

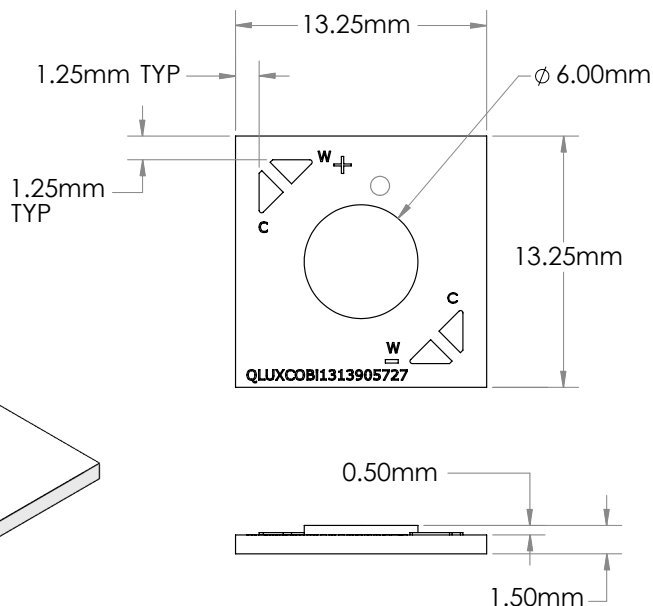
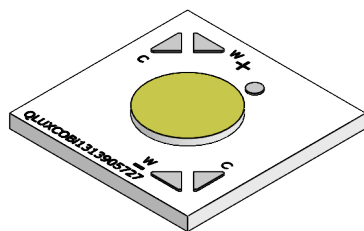

**RECOMMENDED LTF LED DRIVER**

Model	Power	Input	Constant Current Output	Voltage Range	Dimming
DS10W700C0512LTLI6-0060	10W	100-277V AC 0.1A, 50/60Hz	700mA / 2 Channels	5V - 12V DC	ELV, Triac, 0-10V

**ABSOLUTE MAXIMUM RATINGS**

Parameter	Maximum Rating	
Allowable Reverse Current ( $I_R$ )	20mA	
LED Junction Temperature ( $T_J$ )	130°C	
Storage Temperature	-40°C to +125°C	
Operating Case Temperature ( $T_c$ )	100°C	
Soldering Temperature	380°C or lower, 5 seconds max.	
Maximum Total Drive Current	700 mA	
Maximum Drive Current Per Channel	<b>Warm Channel</b>	<b>Cool Channel</b>
	700 mA	700 mA
Maximum Total Power	8W	



**L.T.F.**

## QLUX Light Tune COB LED Series



**LTCOBi1313905727 Dual Channel  
Color Tunable Chip on Board LED**

### SPECTRORADIOMETRIC CHARACTERISTICS

Warm Channel Only (280mA, No Dimming,  $T_j=25^\circ\text{C}$ )

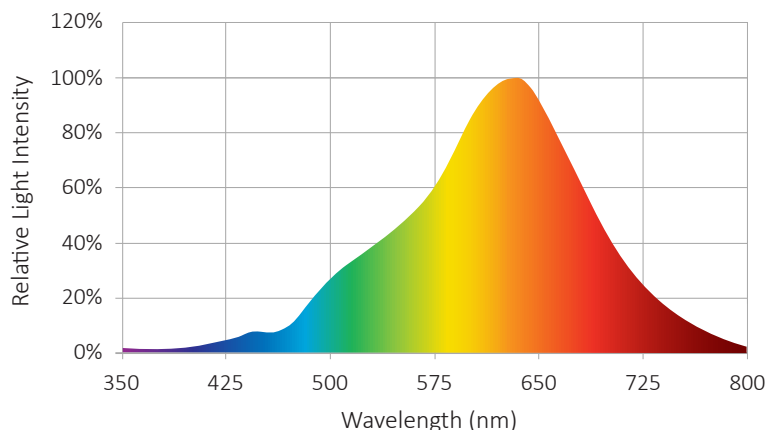

**CCT:** 2285K  
**Luminous Flux:** 210.44 lm  
**Efficacy:** 87.7 lm/W  
**Nominal CCT:** ANSI\_2700K  
 $x_0=0.4590$   $y_0=0.4120$   
**Chromaticity Coordinates:**  
 $x=0.5110$   $y=0.4359$   $u'=0.2835$   $v'=0.5442$   
**Chromaticity Difference:** -0.00281Duv  
**Dominant Wavelength:** 583.0 nm(E)  
**Peak Wavelength:** 630 nm

### CRI TEST RESULTS

Warm Channel Only (280mA, No Dimming,  $T_j=25^\circ\text{C}$ )

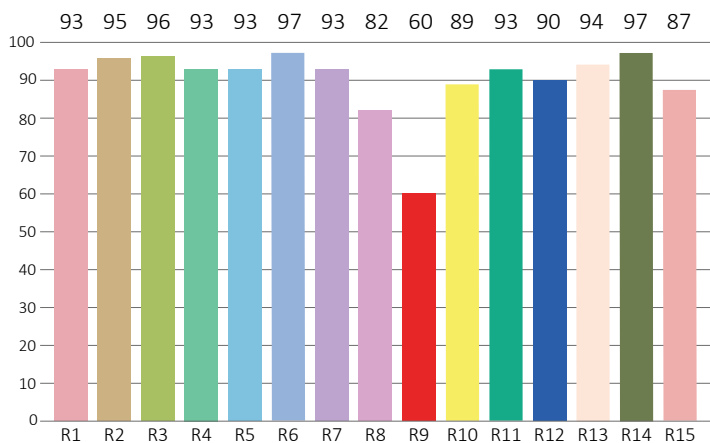

**Color Rendering Index (CRI):** Ra = 92.7  
**Colour Fidelity Index:** Rf = 84  
**Gamut Index:** Rg = 86  
**Purity:** 0.8496  
**Color Ratio:** Kr=51.1% Kg=43.1% Kb=5.8%  
**Color Tolerance (SDCM):** 27.5  
**Bandwidth:** 125.3 nm  
**Radiant Flux:** 0.804 W  
**Photosynthetically Active Radiation (PAR):** 0.74W  
**Photosynthetic Photon Flux (PPF):** 3.76  $\mu\text{mol/s}$

R1=93	R2=95	R3=96	R4=93	R5=93	R6=97	R7=93	R8=82
R9=60	R10=89	R11=93	R12=90	R13=94	R14=97	R15=87	Re=90



IES TM30-18 COLOR RENDERING REPORT

Warm Channel Only (280mA, No Dimming,  $T_j=25^\circ\text{C}$ )

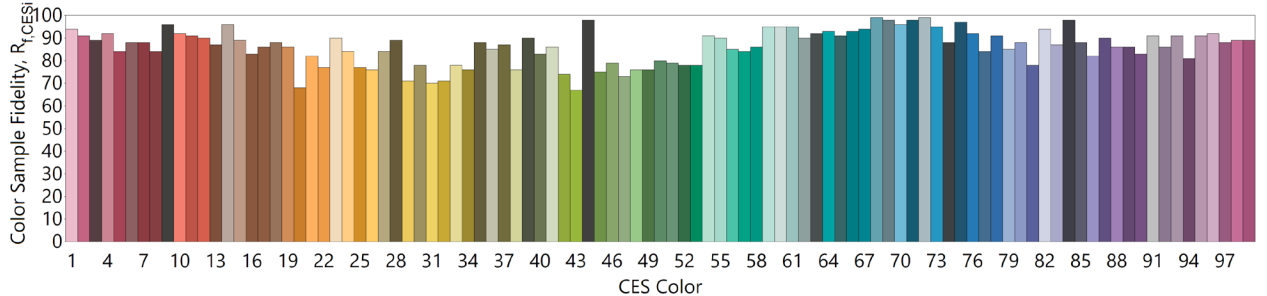
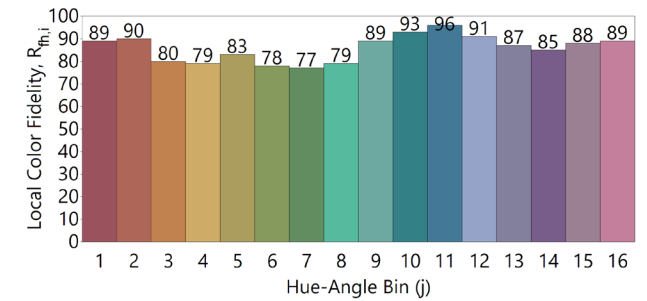
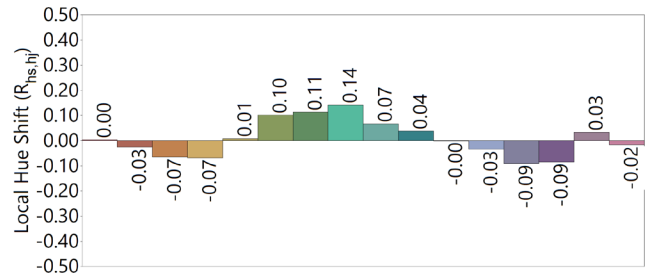
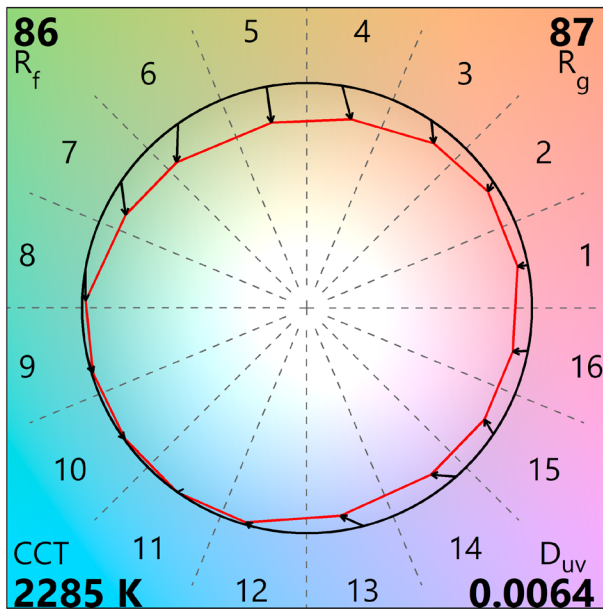
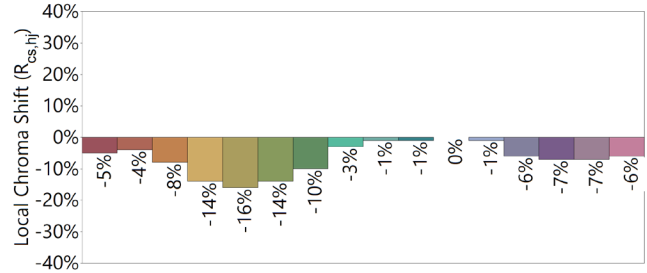
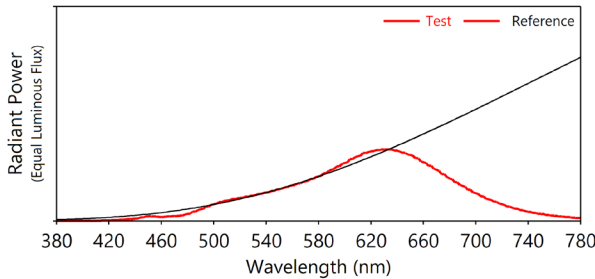



**L.T.F.**

## QLUX Light Tune COB LED Series



**LTCOBi1313905727 Dual Channel  
Color Tunable Chip on Board LED**

### SPECTRORADIOMETRIC CHARACTERISTICS

Cool Channel Only (300mA, No Dimming,  $T_j=25^\circ\text{C}$ )

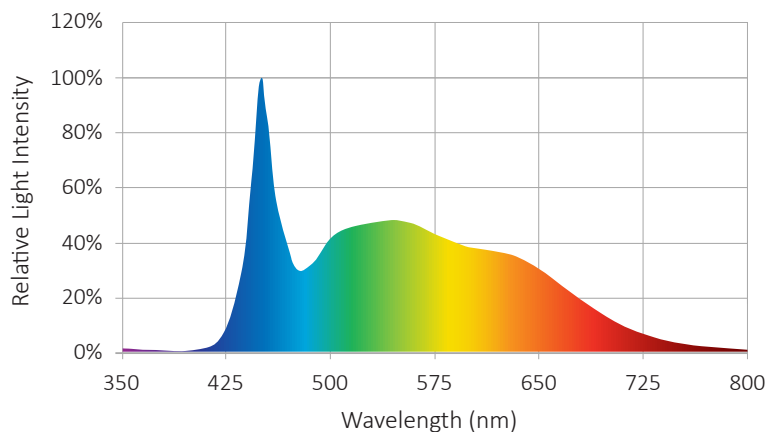

**CCT:** 6528K  
**Luminous Flux:** 314.76 lm  
**Efficacy:** 121.1 lm/W  
**Nominal CCT:** ANSI\_6500K  
 $x_0=0.3130$   $y_0=0.3370$   
**Chromaticity Coordinates:**  
 $x=0.3120$   $y=0.3308$   $u'=0.1967$   $v'=0.4692$   
**Chromaticity Difference:** -0.00281Duv  
**Dominant Wavelength:** 583.0 nm(E)  
**Peak Wavelength:** 630 nm

### CRI TEST RESULTS

Cool Channel Only (300mA, No Dimming,  $T_j=25^\circ\text{C}$ )

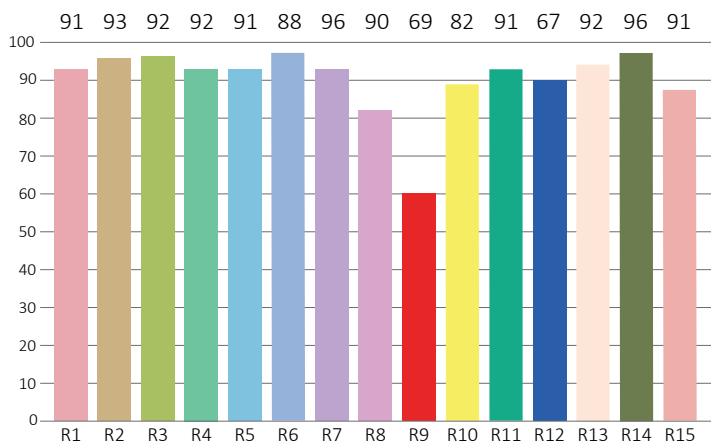

**Color Rendering Index (CRI):** Ra = 91.6  
**Colour Fidelity Index:** Rf = 88  
**Gamut Index:** Rg = 98  
**Purity:** 0.0738  
**Color Ratio:** Kr=29.4% Kg=56.1% Kb=14.5%  
**Color Tolerance (SDCM):** 3.6  
**Bandwidth:** 21 nm  
**Radiant Flux:** 1.084 W  
**Photosynthetically Active Radiation (PAR):** 1.05W  
**Photosynthetic Photon Flux (PPF):** 4.8  $\mu\text{mol/s}$

R1=91	R2=93	R3=92	R4=92	R5=91	R6=88	R7=96	R8=90
R9=69	R10=82	R11=91	R12=67	R13=92	R14=96	R15=91	Re=88



IES TM30-18 COLOR RENDERING REPORT

Cool Channel Only (300mA, No Dimming,  $T_j=25^\circ\text{C}$ )

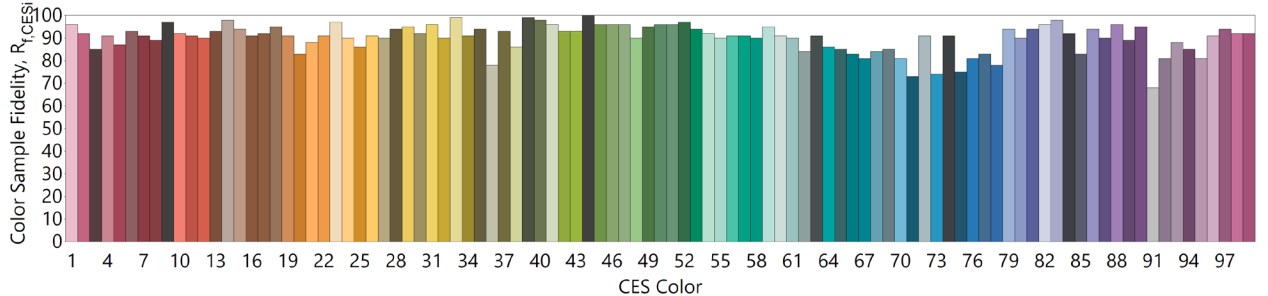
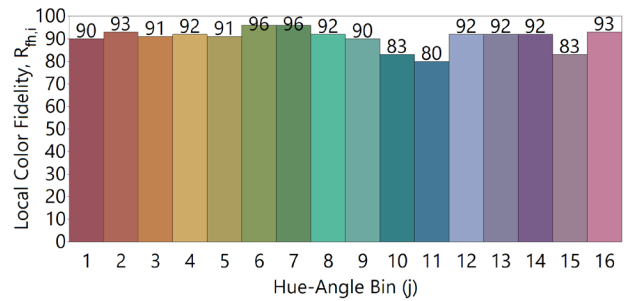
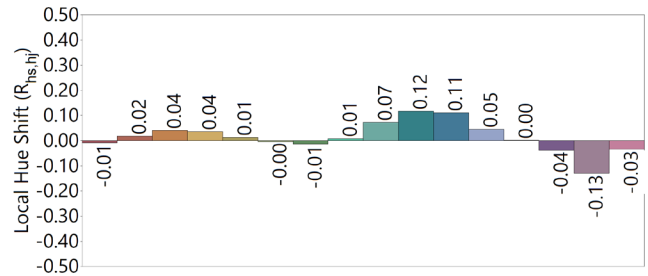
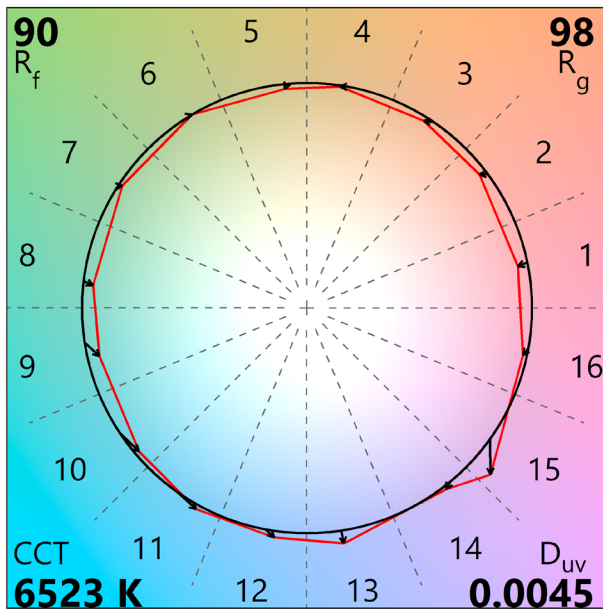
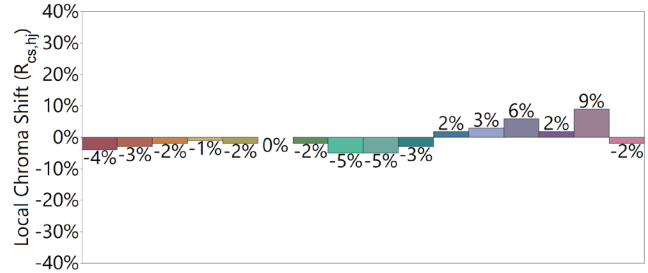
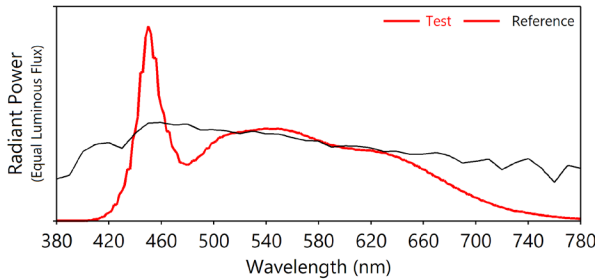



**L.T.F.**

# QLUX Light Tune COB LED Series



**LTCOBi1313905727 Dual Channel  
Color Tunable Chip on Board LED**

## PERFORMANCE CURVES

Test Condition: 25°C

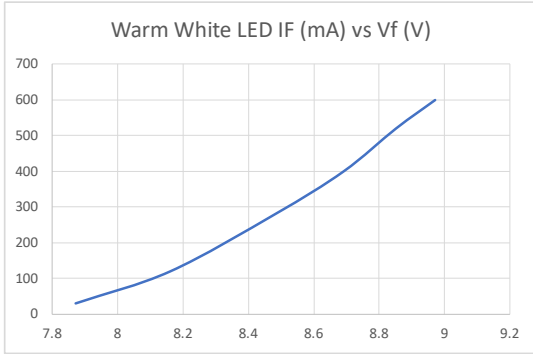

Test Condition: 25°C

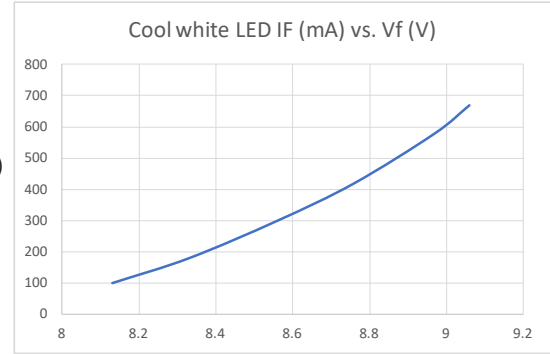

Forward Current (mA)

Forward Current (mA)

Forward Voltage (V)

Forward Voltage (V)

Test Condition: 85°C

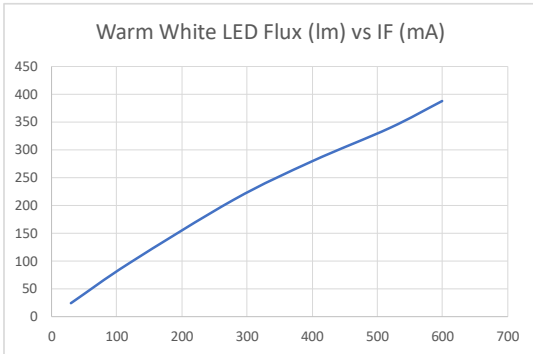

Test Condition: 85°C

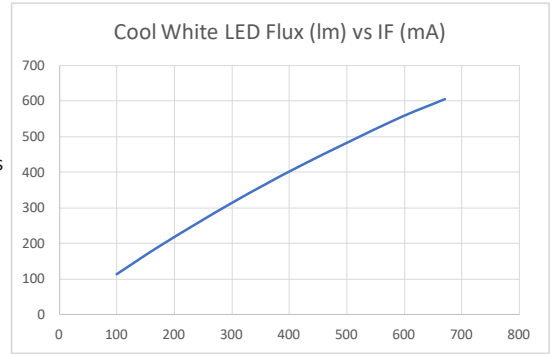

Luminous Flux (lm)

Luminous Flux (lm)

Forward Current (mA)

Forward Current (mA)

Test Condition: 85°C

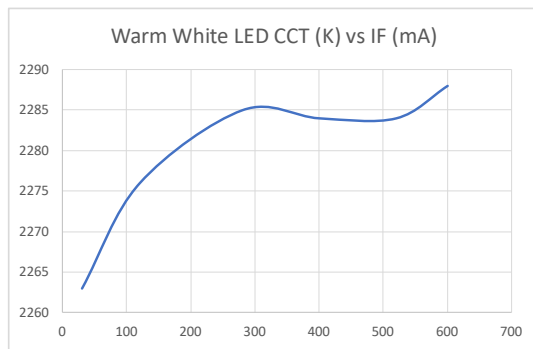

Test Condition: 85°C

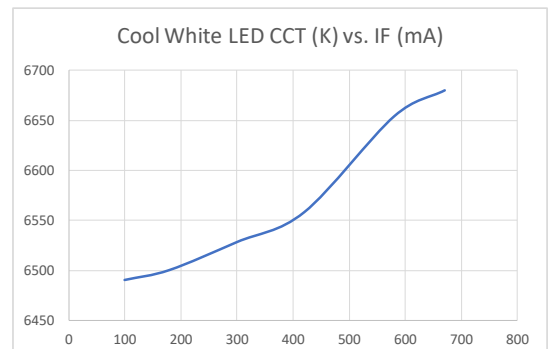

CCT (K)

CCT (K)

Forward Current (mA)

Forward Current (mA)

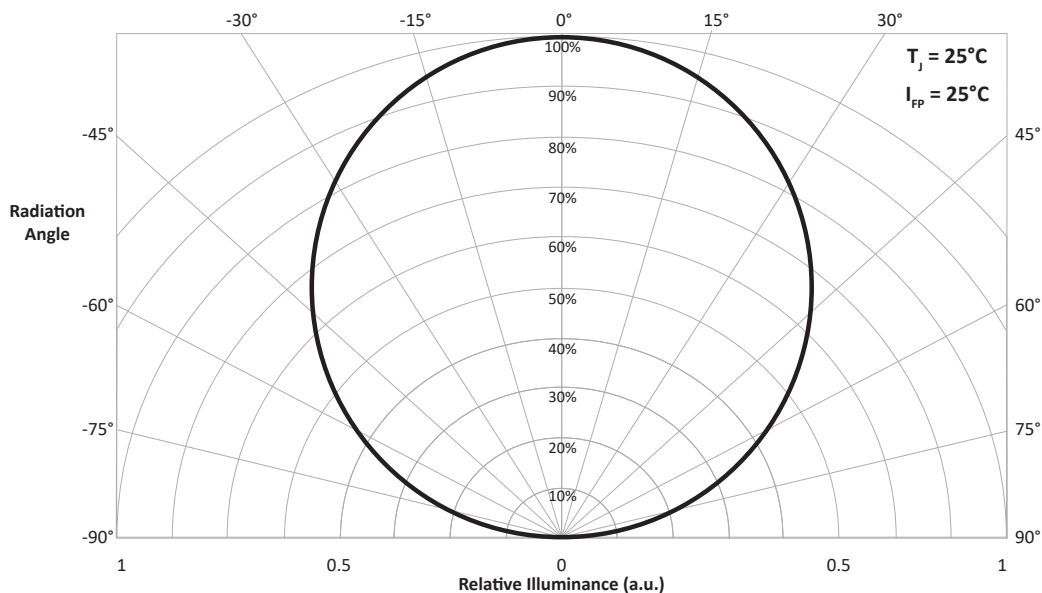
**POLAR RADIATION PATTERN****APPLICATION NOTES**

Operating at a constant current per circuit is recommended.

If constant voltage operation is desired, the circuit shown in figure A is recommended.

The circuit shown in figure B is **not** recommended. In this configuration, normal variations in forward voltage characteristics may cause current to be unstable.

Dimming with pulse width modulation is recommended. Variations in current resulting from other methods of dimming may cause color shifting in the COB.

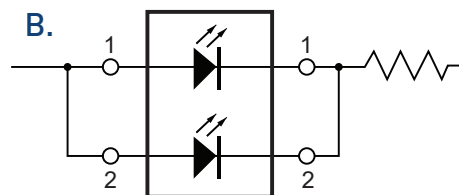
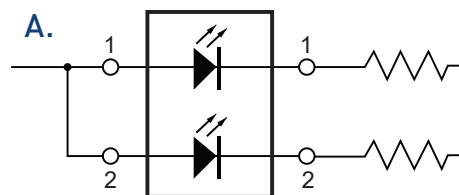





L.T.F.

## QLUX Light Tune COB LED Series



### LTCOBi1313905727 Dual Channel Color Tunable Chip on Board LED

#### PRECAUTIONS FOR USE

**Caution:** Do not touch or apply pressure to the light emitting surface (LES) of the COB. Doing so may damage the LED array.

Do not mount reflectors or optics in contact with the LES.

Contact with surfaces of the COB outside of the LES is acceptable for mounting optical devices.

Do not handle COB with bare hands - oils from skin may contaminate the light emitting surface and affect light output.

Apply thermal grease between COB and fixture housing / heat sink to ensure efficient dissipation of excess heat.

Electrostatic discharge (ESD) and excessive transient voltages may damage the COB. Take precautions such as grounded wrist straps and ESD mats when installing / handling the COB.

#### STORAGE CONDITION

##### Before opening sealed packaging:

- Temperature 5°-30°C
- Relative humidity less than 60%.

##### After opening:

- Temperature 5°-30°C
- Relative humidity less than 60%.
- Apply solder within one week of opening.
- LED should be kept in moisture proof foil bag with silica gel desiccant packet.

#### CHEMICAL COMPATIBILITY

Certain compounds can be absorbed by the resin that encapsulates the light emitting surface, potentially causing reactions that may reduce light output or physically damage the COB. The following compounds are not recommended for use with QLUX COBs:

- |               |                         |                          |
|---------------|-------------------------|--------------------------|
| • Acetates    | • Ethers                | • Siloxanes, Fatty Acids |
| • Acetic Acid | • Cl, F or Br compounds | • Sodium Hydroxide       |
| • Acrylates   | • Liquid Hydrocarbons   | • Sulfur Compounds       |
| • Aldehydes   | • Ketones               | • Sulfuric Acid          |
| • Amines      | • Nitric Acid           | • Toluene                |
| • Benzene     | • Phosphoric Acid       | • Xylenes                |
| • Dienes      | • Potassium Hydroxide   |                          |

#### CLEANING

Do not clean COBs with water, benzene and/or thinner. **Use isopropyl alcohol (IPA) only.** If another solvent is used, it may cause the LED package / resin to be damaged. Do not clean COBs with an ultrasonic cleaner.

To clean the COB, moisten a clean non-abrasive cloth with isopropyl alcohol, avoiding excess liquid / drips. Gently wipe COB surfaces (**Do not apply pressure to the light emitting surface**) to remove any dust, finger prints, etc..